

PROCOURT™ SERIES

PROFESSIONAL COURT LIGHTING SYSTEM

DESIGNED TO SUPPORT IES RP-6 PERFORMANCE TARGETS

Intended for use as a Basis of Design lighting system across a range of sports lighting applications.

300W | 400W

SYSTEM CONFIGURATIONS

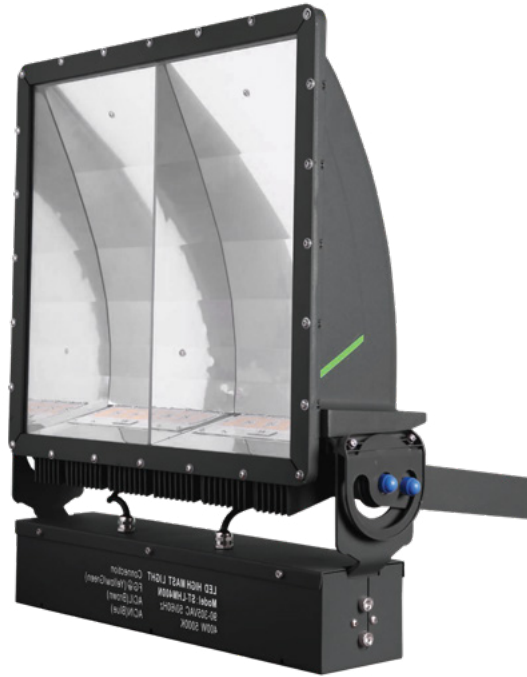

PROJECT SUBMITTAL

PROJECT NAME

TYPE / DESIGNATION

CATALOG NUMBER

SUBMITTED BY

DATE

NOTES / REMARKS

ETL LISTED • DLC PREMIUM • IP65 • BAA COMPLIANT

SYSTEM ENGINEERING

Lighting system performance is achieved through precision-formed aluminum reflector optics engineered for court-specific distributions, with optimized mounting heights and aiming geometry to deliver uniform illumination across the playing surface.

KEY SYSTEM ATTRIBUTES

- Asymmetric aluminum reflector optics
- Controlled glare through optical distribution and aiming
- Mounting heights: 18–30 ft (application dependent)
- Die-cast aluminum housing for outdoor use

SYSTEM OVERVIEW & PERFORMANCE SUMMARY

SYSTEM OVERVIEW

The ProCourt™ Series is a professional-grade LED sports luminaire designed for tennis and pickleball applications requiring controlled glare, uniform illumination, and predictable photometric performance.

The system utilizes a die-cast aluminum housing and precision asymmetric reflector optics optimized for perimeter pole installations.

The forward-throw optical distribution directs light onto the playing surface while limiting high-angle glare and off-site spill light.

Lighting performance to be verified through project-specific photometric calculations, including illumination levels, uniformity, and aiming geometry.

LIGHTING PERFORMANCE IS ACHIEVED THROUGH SYSTEM LEVEL COORDINATION—NOT FIXTURE OUTPUT ALONE.

DESIGNED FOR FULL COMPLIANCE WITH ANSI / IES RP-6 RECOMMENDATIONS.

System design support, photometric layouts, and compliance documentation provided for each project application.

TESTING & COMPLIANCE

Designed to support compliance with:

- IES LM-79
- IES LM-80
- TM-21
- ANSI/IES RP-6
- UL 1598

SYSTEM PERFORMANCE SUMMARY

ATTRIBUTE	PERFORMANCE
Rated Life	L70 ≥ 100,000 hours
Photometric Testing	IES LM-79
LED Lumen Maintenance	IES LM-80 with TM-21 projection
Typical System Efficacy	135–150 lm/W
Color Rendering Index	70 CRI std. (80 CRI opt.)
Power Factor	≥ 0.96 typical
Input Voltage	100–277 V std. (277–480 V opt.)
Operating Temperature	–40°F to 131°F
Ingress Protection	IP65
Surge Protection	10 kV std. (20 kV opt.)
Surge Protection Type	Parallel surge protection
Driver Dimming	0–10 V dimming compatible
External Shielding	Optional glare and spill-light shields available
Warranty	10 years

APPLICATIONS & DESIGN SERVICES



PRIMARY APPLICATIONS

SPORTS FACILITIES

Tennis clubs, pickleball complexes, school athletic courts.

MULTI-SPORT INFRASTRUCTURE

Municipal recreation facilities, multi-court sports complexes.

Additional applications may include golf driving ranges, athletic training facilities, and outdoor sports parks.

TYPICAL MOUNTING CONDITIONS

Typical pole heights: 20–35 ft. Final pole spacing, fixture quantity, and aiming angles shall be determined through project-specific photometric analysis.

ENGINEERING & DESIGN SUPPORT

Duvon provides lighting design support including luminaire selection, mounting configuration, and photometric verification.

Services include:

- AGi32 photometric layouts
- Pole height recommendations
- Mounting option recommendations
- Fixture aiming diagrams
- IES photometric files

These services assist architects, engineers, and municipalities in lighting design verification.

LIGHTING PERFORMANCE STANDARDS

REFERENCE STANDARD

ProCourt luminaires are used in lighting designs developed with reference to ANSI/IES RP-6 recommendations.

LIGHTING CLASS	APPLICATION	IES RECOMMENDED AVG	UNIFORMITY (AVG:MIN)
Class IV	Recreational Play	20–30 fc	≤ 3.0:1
Class III	High School / Club Competition	30–50 fc	≤ 2.5:1
Class II	Club / Regional Competition	50–75 fc	≤ 2.0:1

Glare control strategies may be incorporated to meet project-specific glare rating (GR) requirements where specified. Final illumination levels and uniformity should be verified through project-specific photometric simulation.

VERTICAL ILLUMINANCE CONSIDERATIONS

Sports lighting systems may evaluate vertical illumination levels to support player visibility and ball tracking performance. Vertical illumination is particularly important in tennis where players track the ball above the playing surface.

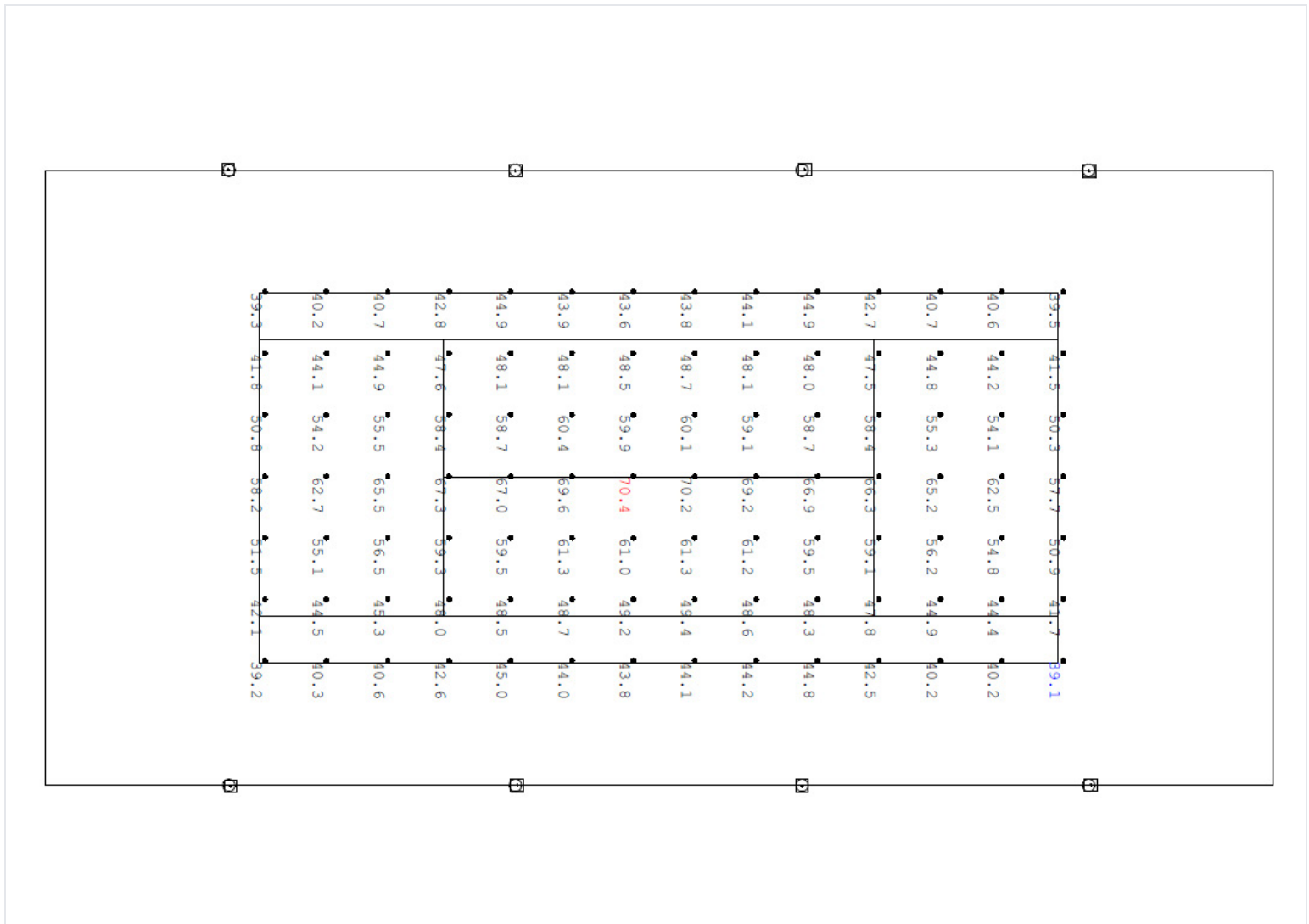

Sample photometric calculation – Single Tennis Courts 60x120ft, 8x24ft–400W – Design 18ft away, Fixed

OPTICAL DISTRIBUTIONS

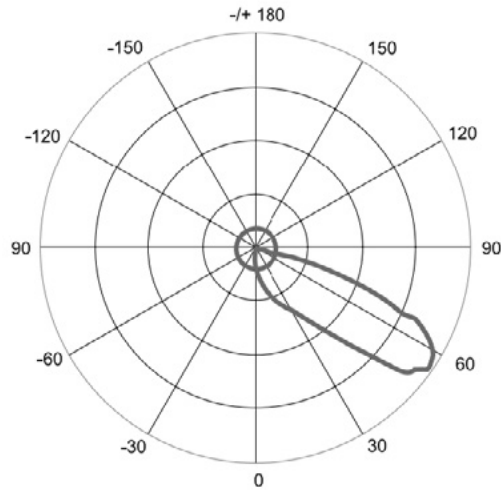

OPTICAL TYPE	DISTRIBUTION	APPLICATION
CA	Court Asymmetric	Tennis and pickleball courts

OPTICAL ORIENTATION

The optical system is designed so that the forward-throw distribution aligns with the playing surface when the luminaire is mounted on perimeter poles outside the court boundary.

OPTICAL MATERIAL

Precision-formed aluminum reflector system engineered to maintain distribution accuracy and long-term outdoor performance.

SHIELDING OPTIONS

External shielding options are available to support stricter zoning requirements and reduced light trespass in residential-adjacent installations.

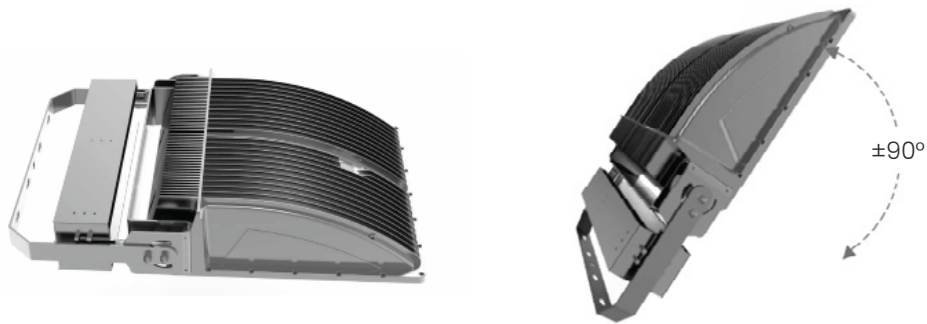

GLARE CONTROL & LIGHT TRESPASS

PRECISION ASYMMETRIC OPTICS

ProCourt luminaires utilize precision asymmetric optics designed to control glare while maintaining illumination levels across the playing surface. Internal optical control and optional external shielding may be used to support reduced light trespass and improved visual comfort. Lighting designs may be evaluated for property-line illumination levels to reduce spill light toward adjacent residential areas.

SKY GLOW & UPLIGHT CONTROL

Optical system designed to limit high-angle light and reduce uplight through controlled beam distribution and proper aiming.

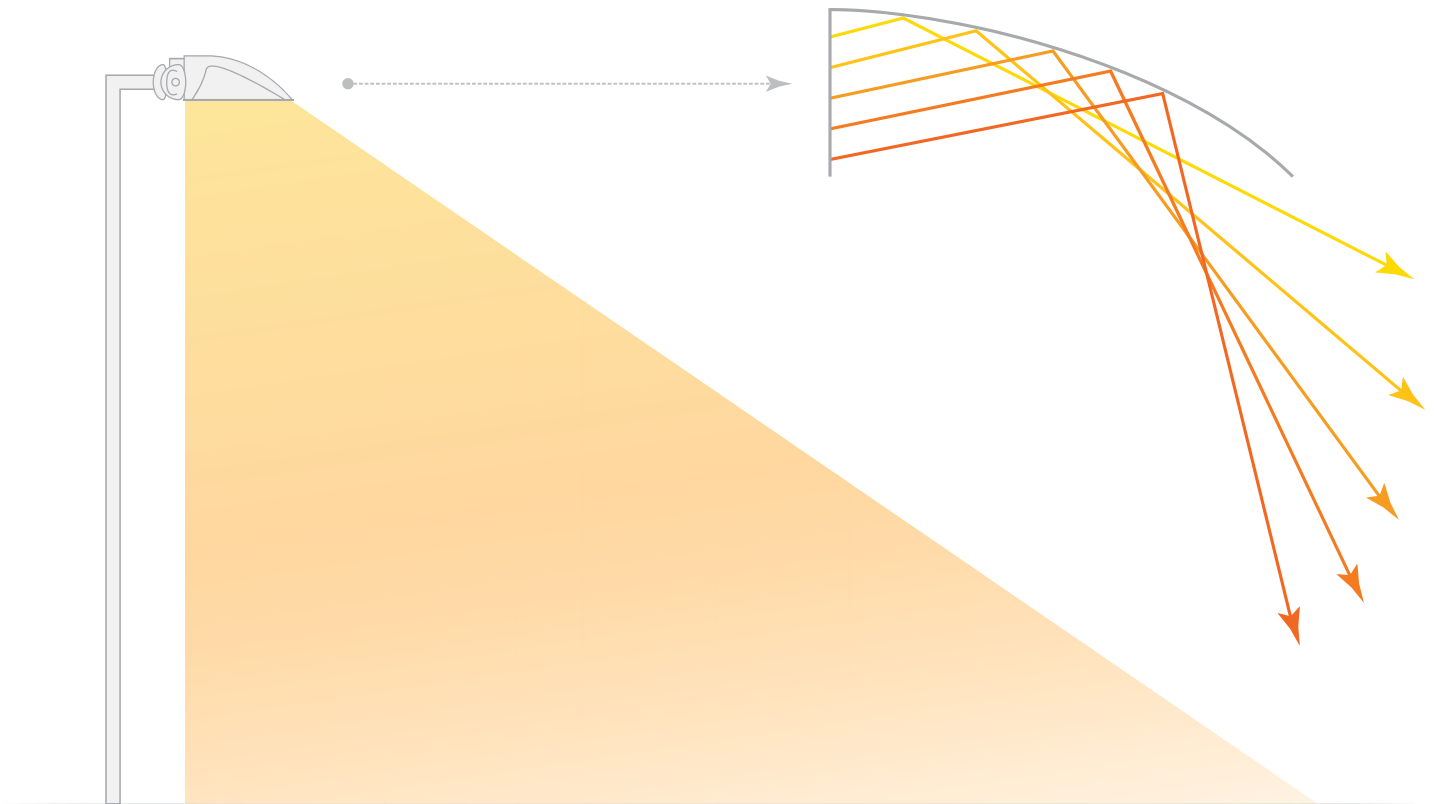

PROPERTY-LINE CONTROL STATEMENT

Property-line illumination levels and spill-light control should be verified through project-specific photometric simulation based on actual site geometry and aiming conditions.

ELECTRICAL & MECHANICAL SPECIFICATIONS

LUMEN OUTPUT

MODEL	WATTS	LUMEN OUTPUT
PROCOURT-300	300 W	42,665 lm
PROCOURT-400	400 W	54,495 lm

TYPICAL SYSTEM EFFICACY

135–150 lm/W

Depending on wattage, CCT, and driver configuration.

AVAILABLE CCT OPTIONS

4000K | 5000K

INPUT CURRENT (AMPERAGE)

VOLTAGE	300W	400W
120V	2.50 A	3.33 A
208V	1.44 A	1.92 A
240V	1.25 A	1.67 A
480V	0.63 A	0.83 A

Input current values are nominal. Final branch circuit sizing shall be verified in accordance with NEC and project requirements.

ELECTRICAL CHARACTERISTICS

ATTRIBUTE	PERFORMANCE
Driver Type	Constant Current LED Driver
Power Factor	≥ 0.96
THD	< 20%
Input Frequency	50/60 Hz
Dimming	0–10 V



MAINTENANCE CONSIDERATIONS

LED luminaires require minimal routine maintenance compared with traditional HID sports lighting systems. Typical maintenance consists of periodic inspection of mounting hardware and cleaning of optical surfaces where required.

MECHANICAL CONSTRUCTION

COMPONENT	SPECIFICATION
Housing	Die-cast aluminum
Optical System	Precision asymmetric sports reflector
Hardware	Stainless steel external fasteners
Mounting	Adjustable yoke bracket
Tilt Adjustment	±90°
Finish	Powder coating, 1,000-hour salt-spray tested

FINISH COLORS

- Black (std.)
- Bronze
- Gray
- Green

OPTIONAL MOUNTING ACCESSORIES

- 2-3/8 in round slip-fitter adapter
- Rectangular pole slip-fitter adapter

FIXTURE WEIGHT (LUMINAIRE ONLY)

MODEL	WEIGHT
PROCOURT-300	44.1 lbs
PROCOURT-400	49.1 lbs

EFFECTIVE PROJECTED AREA (EPA)

0.96 ft²



STRUCTURAL CONSIDERATIONS

Pole structures shall be designed in accordance with local wind load requirements (typically 115–150 mph). Final pole design must be verified by a licensed structural engineer.

SMART CONTROL SYSTEM

Duvon sports lighting systems support wireless lighting control platforms.

Control capabilities include:

- Remote on/off control
- Scheduled operation
- Energy monitoring
- Remote diagnostics

TYPICAL LIGHTING SCENES

- Practice Mode
- Recreational Play
- Tournament Play
- Maintenance Lighting

Control architecture:

- Wireless control nodes integrated with luminaires
- Central gateway controller
- Mobile or web-based management interface

SYSTEM PERFORMANCE VERIFICATION

Lighting systems utilizing Duvon sports luminaires include project documentation such as:

- Photometric reports verifying illumination levels & uniformity
- Pole layout drawings
- Fixture aiming diagrams
- IES photometric files
- Electrical load information
- Structural data including fixture weight and EPA values

DIMENSIONAL DATA

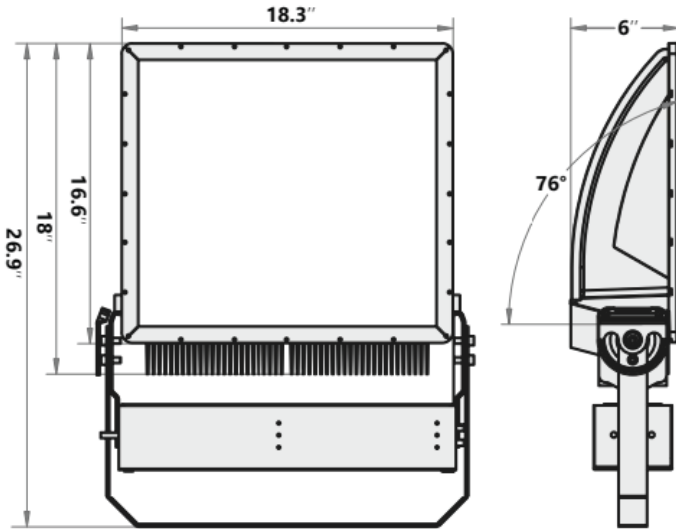

★ YOKE BRACKET DRAWING

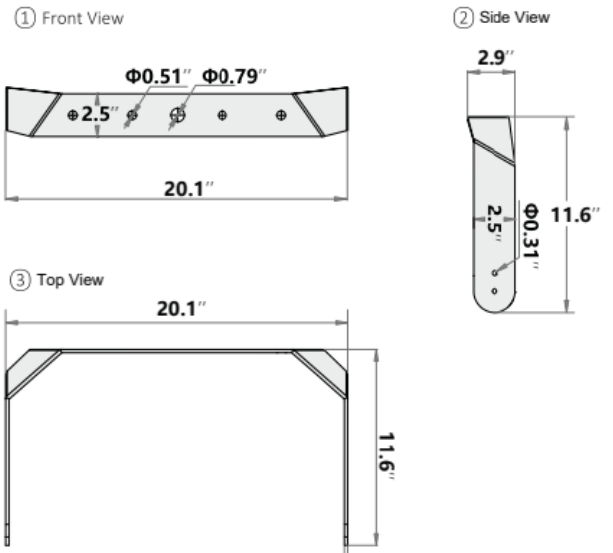

ORDERING INFORMATION & SUBMITTAL SCHEDULE

MODEL SELECTION BUILDER

MODEL	WATTS	CCT	CRI	VOLTAGE	MOUNT	OPTIC	FINISH	CONTROL	OPTIONS
PROCOURT	300	40K	70	STD	YK	CA	BLK	WL	SPD20
	400	50K	80	HV			BRZ		SH
			90				GRY		
							GRN		

Bold values indicate standard configuration.

CATALOG NUMBER EXAMPLE

PROCOURT-400-50K-70-HV-YK-CA-BLK-WL-SPD20

CONFIGURATION CODES

CCT

40K = 4000K

50K = 5000K

VOLTAGE

STD = 100-277V

HV = 277-480V

MOUNT

YK = YOKE BRACKET

OPTICS

CA = COURT ASYMMETRIC

FINISH

BLK = BLACK

BRZ = BRONZE

GRY = GRAY

GRN = GREEN

CONTROL

WL = WIRELESS MESH

OPTIONS

SPD20 = 20 KV SURGE PROTECTION

SH = EXTERNAL SHIELD

FIXTURE SCHEDULE

TYPE	CATALOG NUMBER	QTY

Final configuration shall be verified against project-specific electrical and photometric requirements.

DUVON LIGHTING LLC

710 ARMSTRONG DR. • BUFFALO GROVE, IL 60089

P: (224) 567-8312 E: SALES@DUVONLIGHTING.COM WWW.DUVONLIGHTING.COM



PROCOURT™ SERIES
SPECIFICATIONS SUBJECT TO CHANGE WITHOUT NOTICE